



12.4 GHz    N    N/O    S.P.4 T. SWITCH

OPTIONS : / TTL DRIVE / SUPP.DIODES

**R F CHARACTERISTICS**

NUMBER OF WAYS : 4  
 FREQUENCY RANGE : 0 - 12.4 GHz  
 IMPEDANCE : 50 Ohms

FREQUENCY (GHz)	0 - 3	3 - 8	8 - 12.4
V.S.W.R <=	1.20	1.35	1.50
INSERT. LOSS <=	0.20 dB	0.35 dB	0.50 dB
ISOLATION >=	80 dB	70 dB	60 dB
AVER. POWER (*)	300 W	200 W	150 W

**ELECTRICAL CHARACTERISTICS**

ACTUATOR : NORMALLY OPEN  
 NOMINAL CURRENT AT 25° C (±10%) : 250 mA  
 ACTUATOR VOLTAGE (Vcc) : 12V (10.2 to 13V) / NEGATIVE COMMON  
 TERMINALS : solder pins (250°C max./30 sec.)  
 TTL INPUTS (E) - High level : 2.2 to 5.5V / 800µA at 5V  
                                   - Low level : 0 to 0.8V / 20µA at 0.8V

**MECHANICAL CHARACTERISTICS**

CONNECTORS : N female per MIL C 39012  
 LIFE : 2.000.000 cycles per position  
 SWITCHING TIME (nominal voltage;25° C) : < 15 ms  
 CONSTRUCTION : splashproof  
 WEIGHT : < 460 g

**ENVIRONMENTAL CHARACTERISTICS**

OPERATING TEMPERATURE RANGE (°C) : -40 , +85  
 STORAGE TEMPERATURE RANGE (°C) : -55 , +85

(\* : average power at 25° C per RF path)

4112-9212 This information is given as an indication. In the continual goal to improve our products, we reserve the right to make any modifications judged necessary

4113-9212 This information is given as an indication. In the continual goal to improve our products, we reserve the right to make any modifications judged necessary

**DRAWING**

General tolerance: ± 0,5 mm

**R573 102420**

Page  
2/2

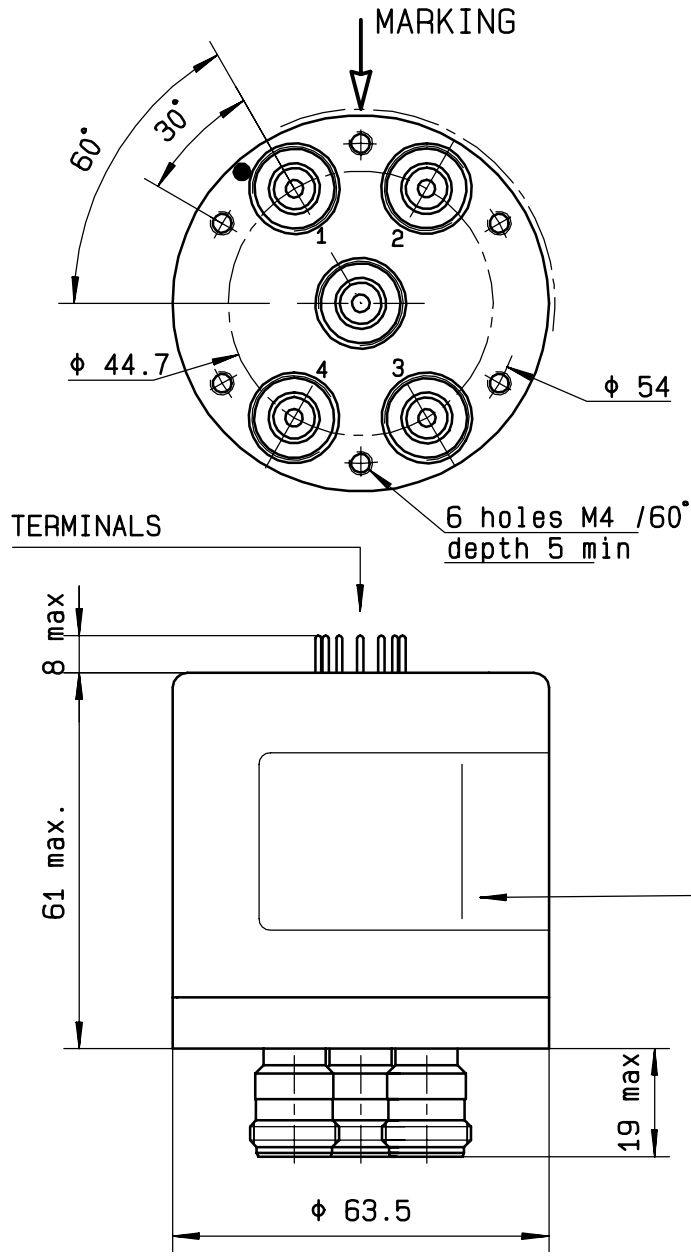

TTL input	RF continuity
E1 = 1	IN ↔ 1
E2 = 1	IN ↔ 2
E3 = 1	IN ↔ 3
E4 = 1	IN ↔ 4

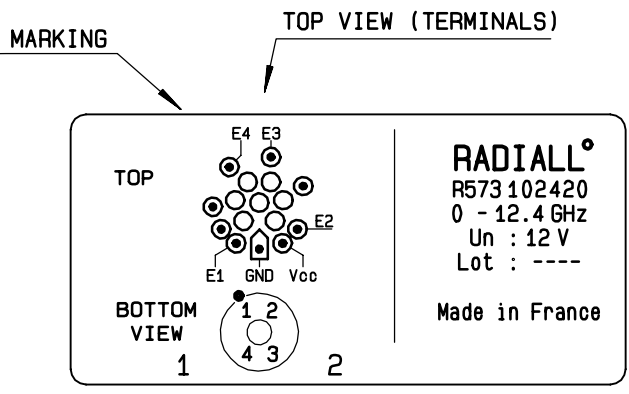

**RADIALL<sup>o</sup>**  
R573 102420  
0 - 12.4 GHz  
Un : 12 V  
Lot : ----  
Made in France

**SCHEMATIC DIAGRAM**

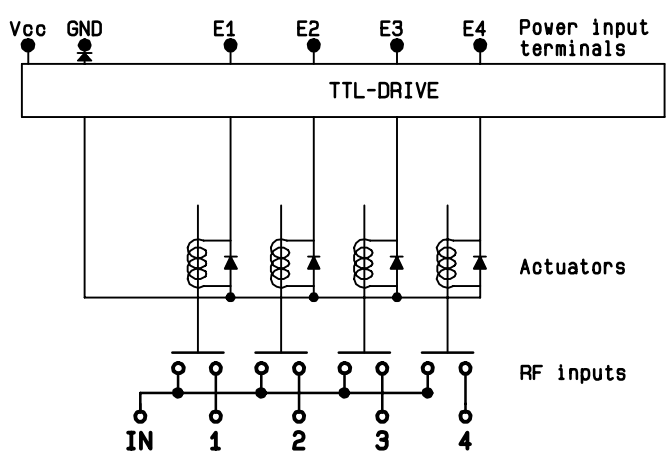

ISSUE 20. Apr. 01